

Adopted by the Board of Selectmen
May 15, 1973
Revised February 28, 2011

**TOWN OF WELLESLEY
POLICY GOVERNING
DRIVEWAY APRONS AND CURB CUTS**

RESIDENTIAL

PURPOSE: To limit potential areas of traffic conflict while maintaining adequate access for vehicles to be stored conveniently off-street.

POLICY: A written curb cut request must be made to the office of the Town Engineer regardless of whether the request is for a new curb cut and driveway apron or alteration to an existing curb cut and driveway apron.

There shall be not more than two (2) driveway aprons and curb cuts per lot. The only exception would be if the request involves a corner lot. Two (2) curb cuts could be permitted on a street to provide for a semi-circular driveway and a third curb cut could be permitted on the intersecting street for access to the garage(s). Under any circumstance, the maximum number of driveway aprons and curb cuts that would be allowed under those conditions is three (3). Under all other conditions, the maximum permissible number of curb cuts shall be two (2).

The standard single driveway width shall not be in excess of 12 feet measured at the property line, but may flare out at the curb line to a greater width as shown in the Town's Standard Construction Detail 2A, appended to this policy.

The standard double driveway width shall not be in excess of 20 feet measured at the property line, but may flare out to a greater width at the curb line as shown in the Town's Standard Construction Detail 2B, appended to this policy.

Permission may be granted by the Town Engineer for a second driveway apron and curb cut if, upon investigation, it is found that construction and maintenance of such driveway will not impair, endanger, or interfere with the public safety.

When two (2) driveway aprons are permitted, there shall be provided at least 20 feet of sidewalk between them for a safety island for pedestrians. Please refer to the Town's Standard Construction Details 2D and 2E for Semi-circular Driveway Aprons, appended to this policy.

Whenever possible, no driveway openings or curb cuts shall be permitted within 50 feet of a street corner measured from the nearest edge of the driveway and the crossroad edge of pavement.

Any decorative or rumble strip that may be placed at the end of the driveway must be constructed on private property, typically 8 feet behind the roadway pavement.

All driveway aprons and curb cuts within the public way shall be constructed of bituminous concrete or cement concrete. Other materials such as gravel, crushed stone, pea stone, cobblestones or brick pavers may be used to construct the driveway on private property. Said construction must begin eight (8) feet beyond the edge of the roadway and shall be constructed solely on private property and not encroach on the public way.

PROCEDURE:

Each request for location or relocation of driveway aprons and curb cuts shall be in writing to the office of the Town Engineer, 2 Municipal Way, Wellesley, MA 02481. Such letter shall state the reasons for the need for the new or expanded curb cut and driveway apron. The request shall include a plan at a **scale of 1" = 40'**, showing the lot, its total area and perimeter dimensions, and approximate location of the house and garage, dimensions of the proposed driveway and existing driveway, the disposition of any existing driveways and all materials to be used in the construction of the proposed curb cut and driveway.

The Town Engineer shall review the request and approve or disapprove the request in accordance with the requirements of this policy.

Should issues arise that cannot be adjudicated between the Town Engineer and the Applicant regarding the proposed driveway apron and curb cut, the Applicant may appeal to the Board of Selectmen.

Once approval has been received from the Town Engineer, the owner of the property or his/her designee shall obtain a **Street Occupancy Permit** from the Department of Public

Works Engineering Division, 2 Municipal Way, Wellesley, MA 02481.

ELECTRONIC SUBMISSION: Requests for new, altered or relocated curb cuts and driveway aprons may also be made electronically by sending one set of all of the information specified herein to: engineering@wellesleyma.gov
If plans cannot be transmitted to scale electronically, all required dimensions must be clearly specified on the plan to permit review of the request.

PENALTIES: Failure to obtain approval of a new, altered or relocated driveway apron or curb cut or any violation of this policy will result in a fine in accordance with Town Bylaw 49.35 in the amount of \$50.00 for each offense. Each offense is defined as each day work has been performed or the driveway apron or curb cut is in place without benefit of approval by the Town Engineer.

COMMERCIAL

POLICY: Curb cut requests for gas stations, parking lots, office buildings, etc., shall be in accordance with the Zoning Bylaws where applicable and subject to review by the Town Engineer. Each request for a permit shall be reviewed on its own merits. The Town's Standard Construction Details 2F and 2G are typical examples of standard commercial driveways. There shall normally not be more than two (2) driveways per commercial development.

PROCEDURE: Each request for a driveway apron or curb cut shall be in writing to the office of the Town Engineer. Such request shall state the reason for the requested driveway and shall be accompanied by a plan at a **scale of 1" = 40'**, showing the lot, total area, perimeter dimensions, location of all structures and the location and dimensions of all proposed driveway aprons and curb cuts, the existing driveway and curb cut, the disposition of any existing driveways and all materials to be used in the construction of the proposed curb cut and driveway.

The Town Engineer shall review the request and approve or disapprove request in accordance with the requirements of this policy.

Should issues arise that cannot be adjudicated between the Town Engineer and the Applicant regarding the proposed

driveway apron and curb cut, the Applicant may appeal to the Board of Selectmen.

Once approval has been received from the Town Engineer the owner of the property or his/her designee shall obtain a **Street Occupancy Permit** from the Department of Public Works Engineering Division.

**ELECTRONIC
SUBMISSION:**

Requests for new, altered or relocated curb cuts and driveway aprons may also be made electronically by sending one set of all of the information specified herein to:

engineering@wellesleyma.gov

If plans cannot be transmitted to scale electronically, all required dimensions must be clearly specified on the plan to permit review of the request.

PENALTIES:

Failure to obtain approval of a new, altered or relocated driveway apron or curb cut or any violation of this policy will result in a fine in accordance with Town Bylaw 49.35 in the amount of \$50.00 for each offense. Each offense is defined as each day work has been performed or the driveway apron or curb cut is in place without benefit of approval by the Town Engineer.



TOWN OF WELLESLEY
 DEPARTMENT OF PUBLIC WORKS
 ENGINEERING DIVISION

2A

SINGLE WIDTH RESIDENTIAL DRIVEWAY STANDARDS

DATE: 01/18/2002

SCALE: NONE

DATE REVISED: 01/27/2011

For Streets With Curbing

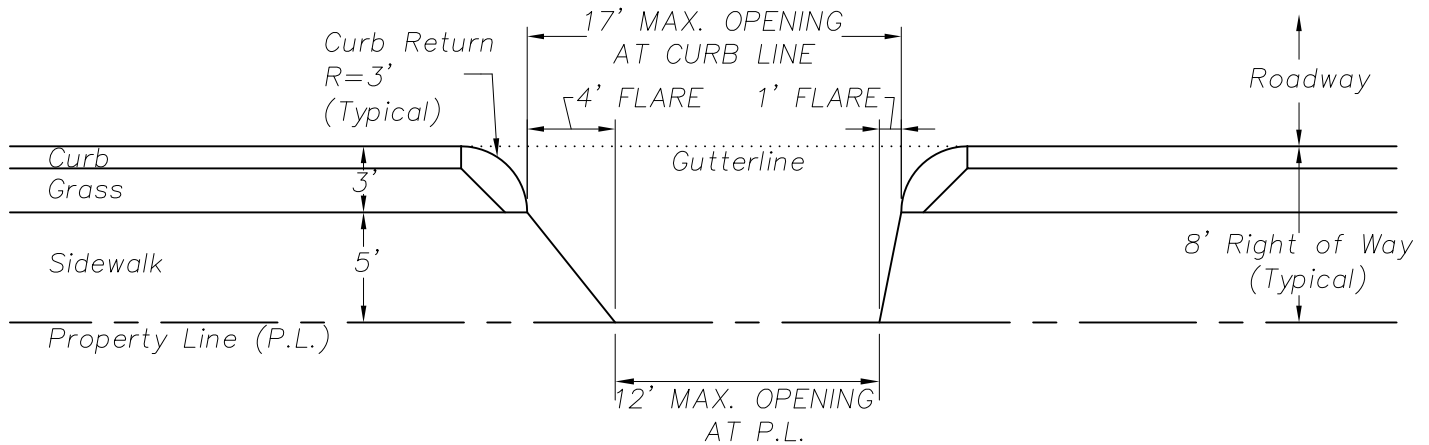

For Streets Without Curbing

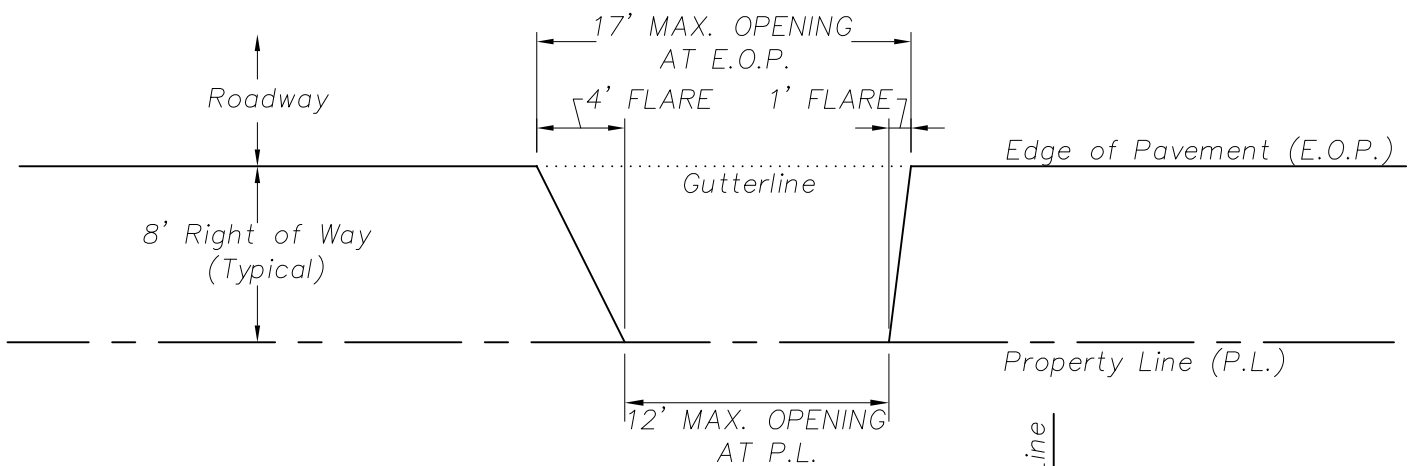

Cross Section

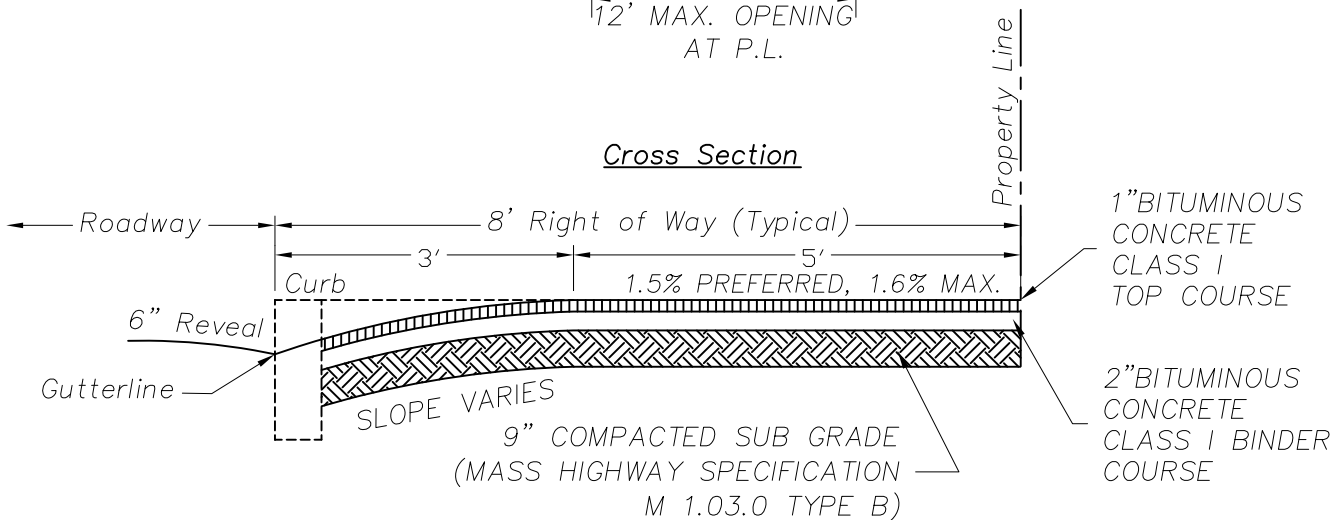

All construction must be in compliance with the Americans with Disabilities Act (ADA).



TOWN OF WELLESLEY
 DEPARTMENT OF PUBLIC WORKS
 ENGINEERING DIVISION

2B

DOUBLE WIDTH RESIDENTAL DRIVEWAY STANDARDS

DATE: 01/18/2002
 DATE REVISED: 01/27/2011

SCALE: NONE

For Streets With Curbing

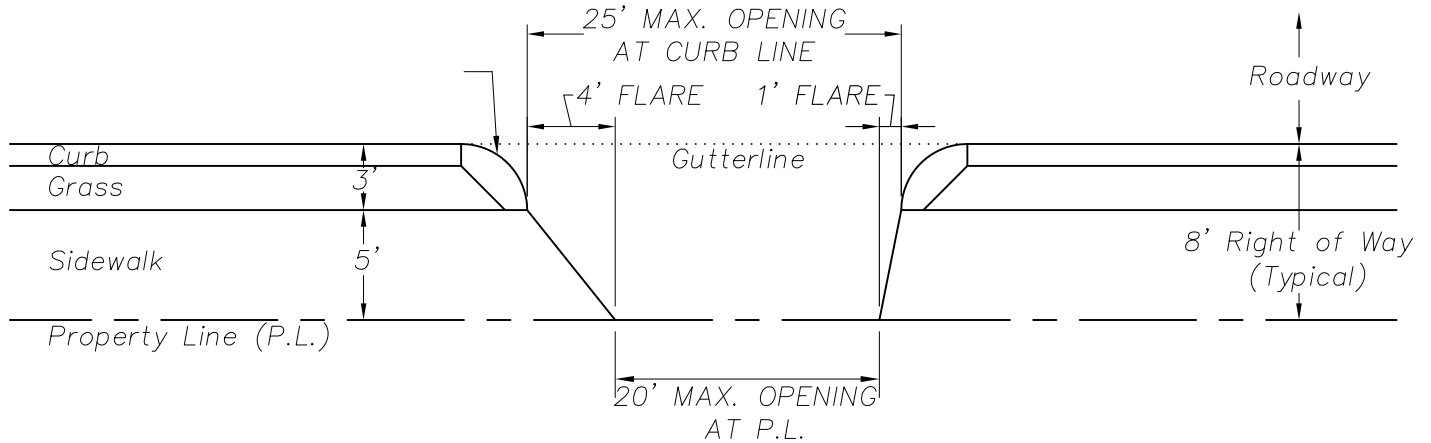

For Streets Without Curbing

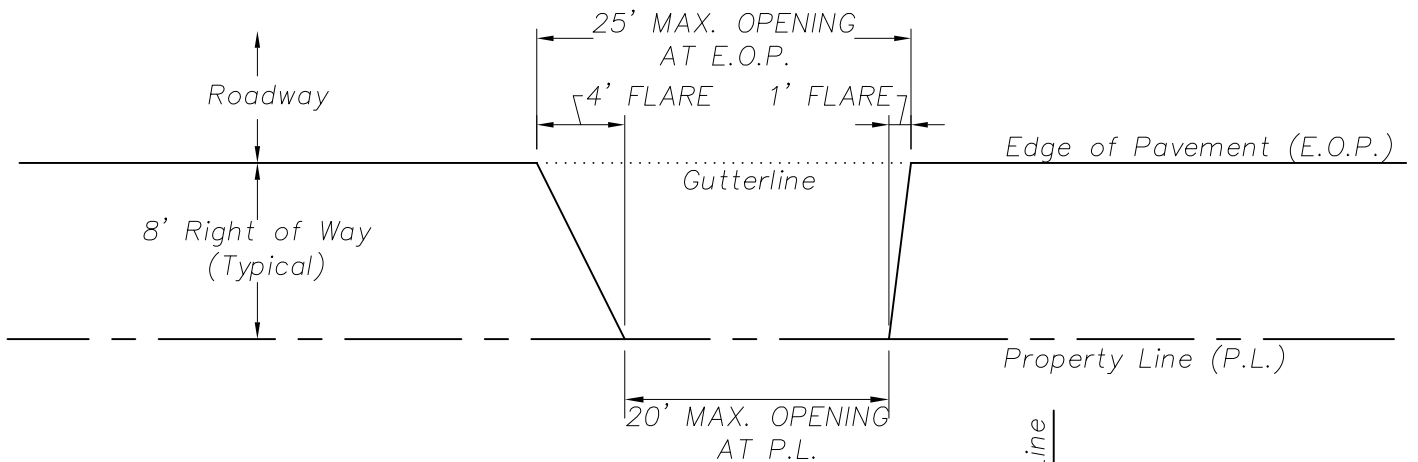

Cross Section

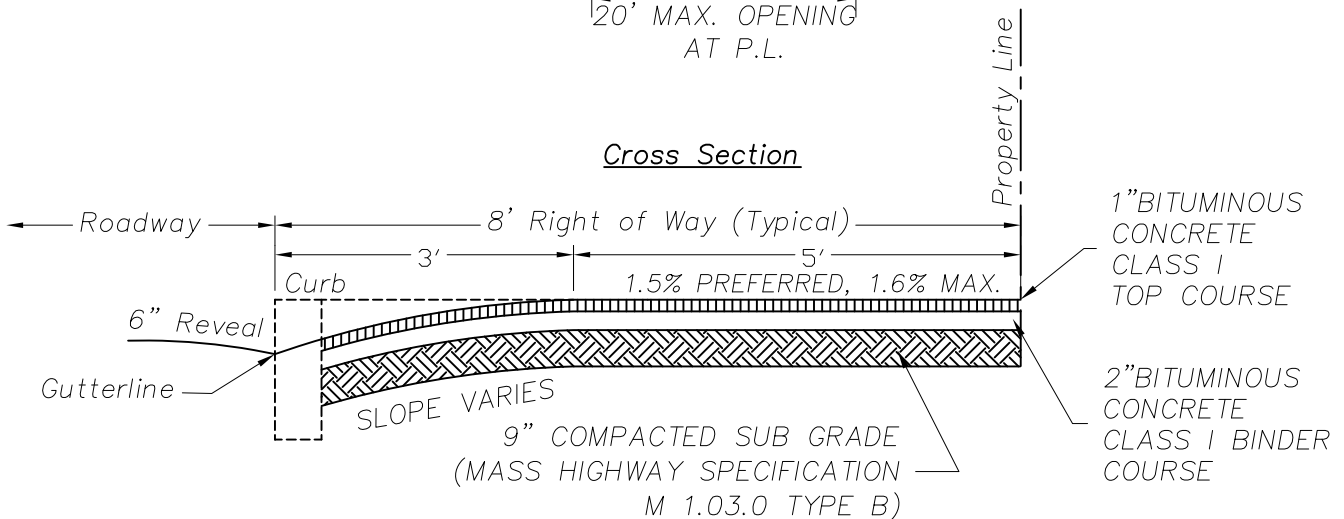

All construction must be in compliance with the Americans with Disabilities Act (ADA).



TOWN OF WELLESLEY
DEPARTMENT OF PUBLIC WORKS
ENGINEERING DIVISION
TYPICAL COMMERCIAL
DRIVEWAY MARKINGS

2C

DATE: 01/18/2002
REVISED: 08/12/2008

SCALE: NONE

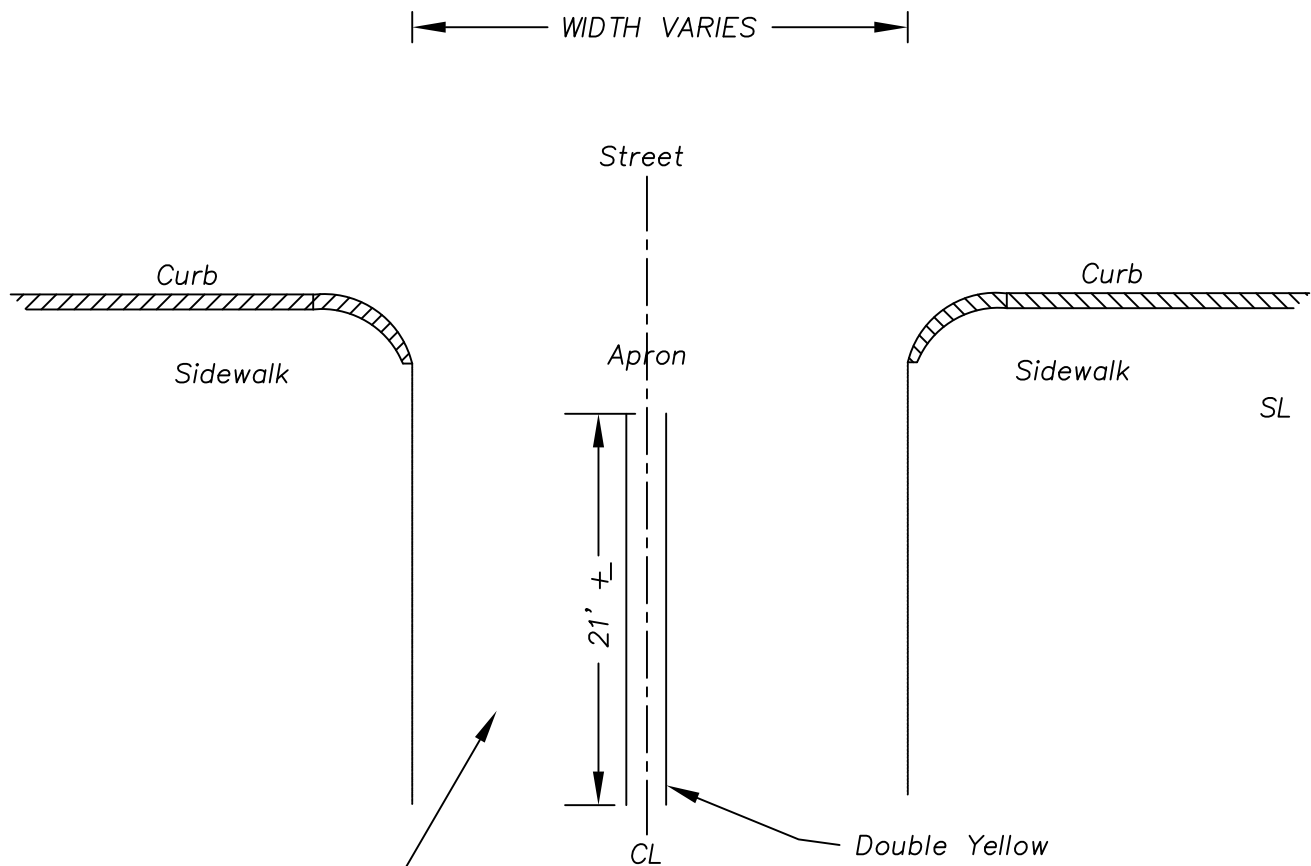

Recommended pavement marking for commercial driveways designed for two-way operation.



TOWN OF WELLESLEY
 DEPARTMENT OF PUBLIC WORKS
 ENGINEERING DIVISION

2D

SINGLE WIDTH RESIDENTAL SEMI-CIRCULAR DRIVEWAY APRON
 WITH OR WITHOUT CURBING

DATE: 01/28/2011
 DATE REVISED: NA

SCALE: NONE

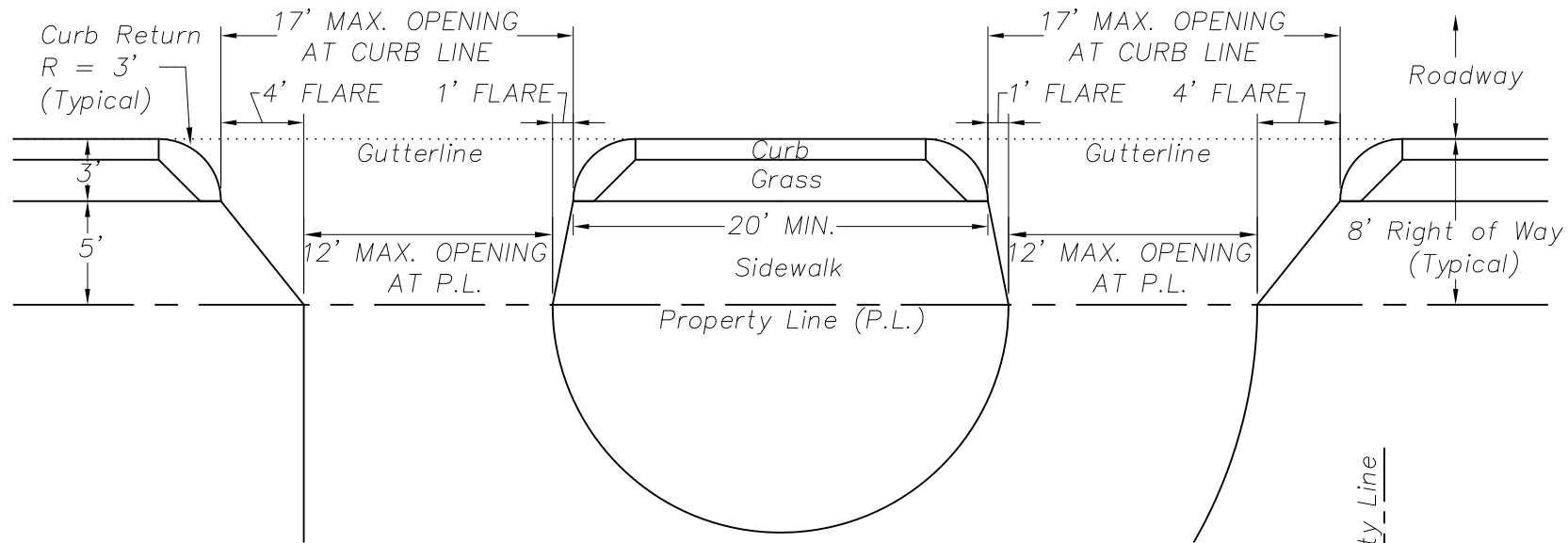

Cross Section

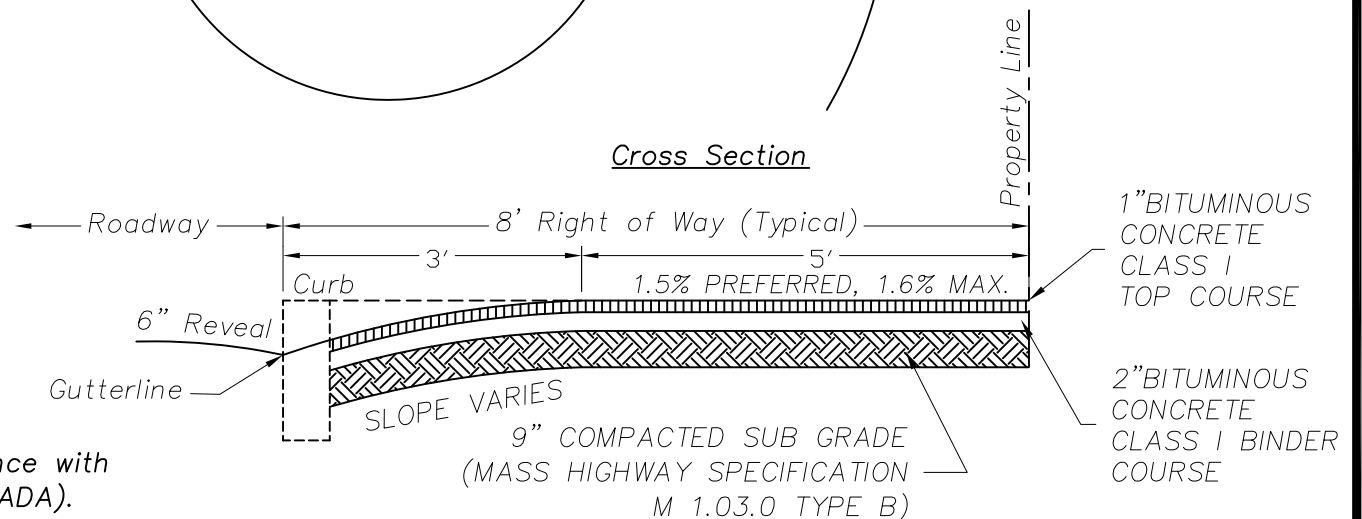

All construction must be in compliance with the Americans with Disabilities Act (ADA).



TOWN OF WELLESLEY
 DEPARTMENT OF PUBLIC WORKS
 ENGINEERING DIVISION

2E

DOUBLE WIDTH RESIDENTAL SEMI-CIRCULAR DRIVEWAY APRON
 WITH OR WITHOUT CURBING

DATE: 01/28/2011
 DATE REVISED: NA

SCALE: NONE

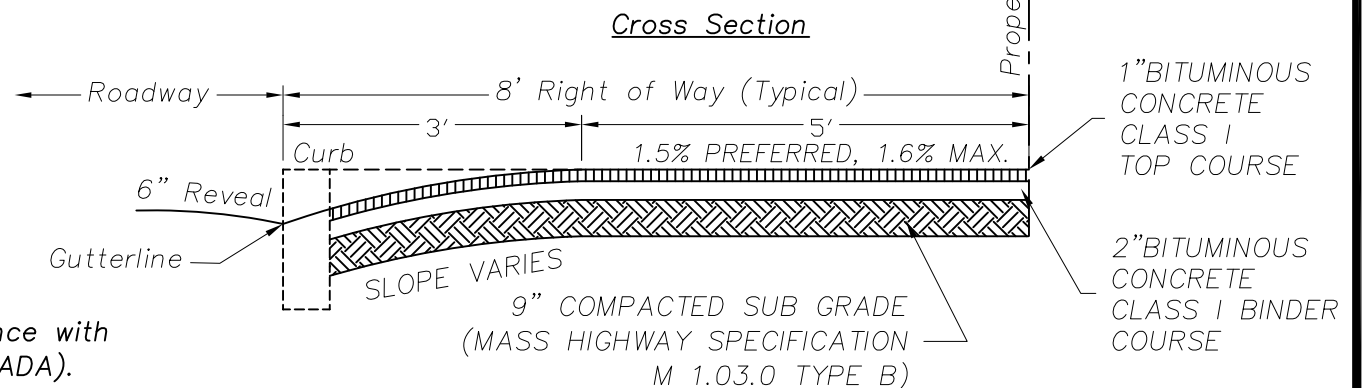
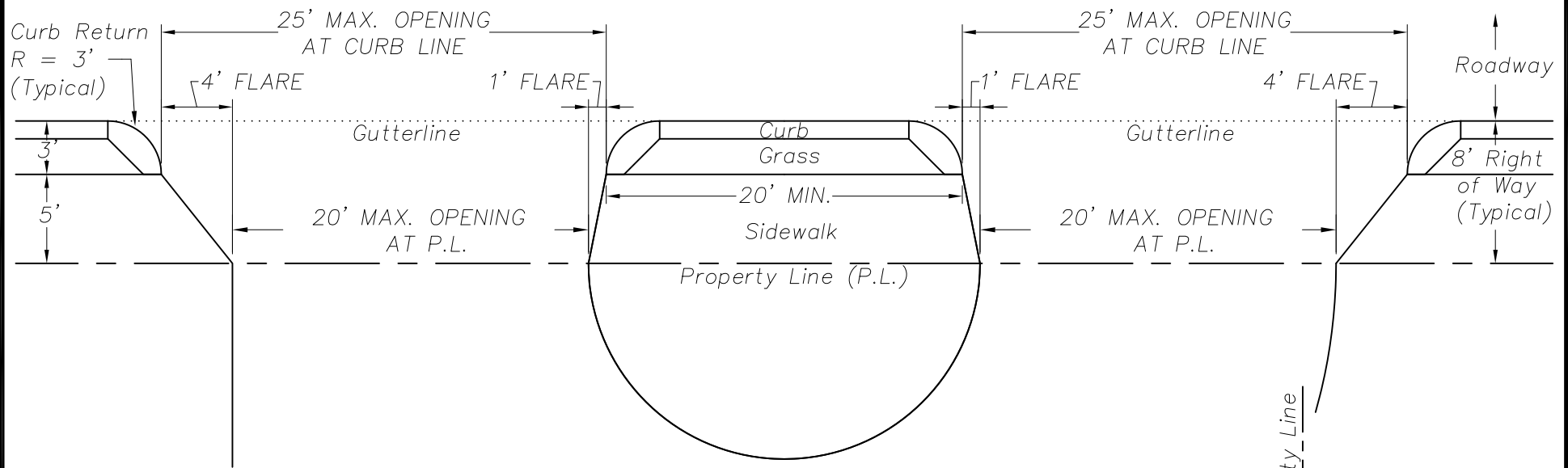

All construction must be in compliance with the Americans with Disabilities Act (ADA).



TOWN OF WELLESLEY
 DEPARTMENT OF PUBLIC WORKS
 ENGINEERING DIVISION
 COMMERCIAL DRIVEWAY APRON STANDARDS

2F

DATE: 01/18/2002
 DATE REVISED: 01/26/2011

SCALE: NONE

Plan View

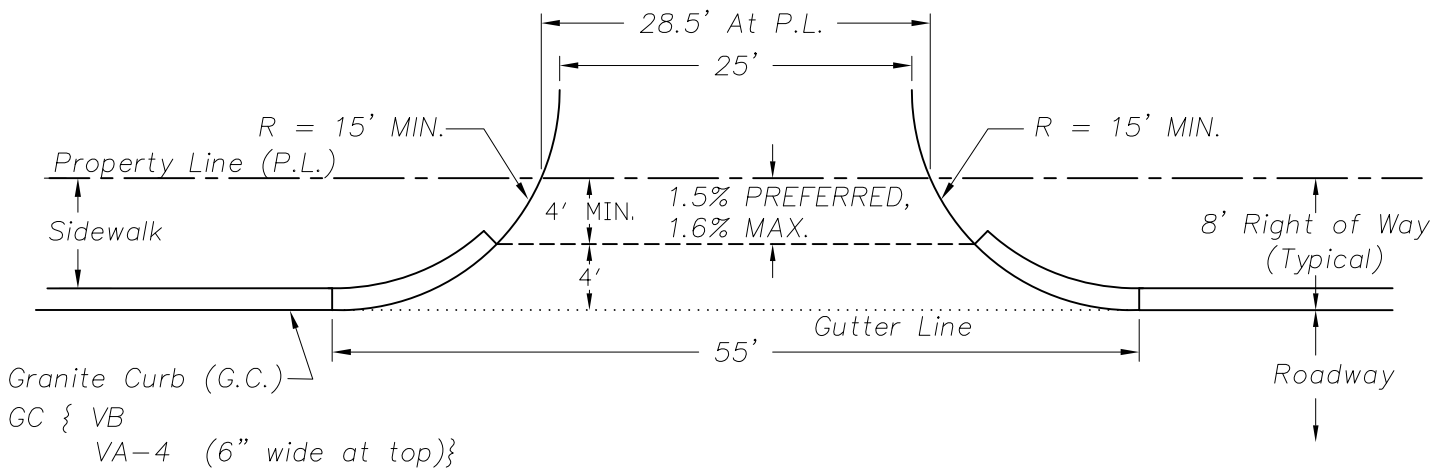

Cross Section

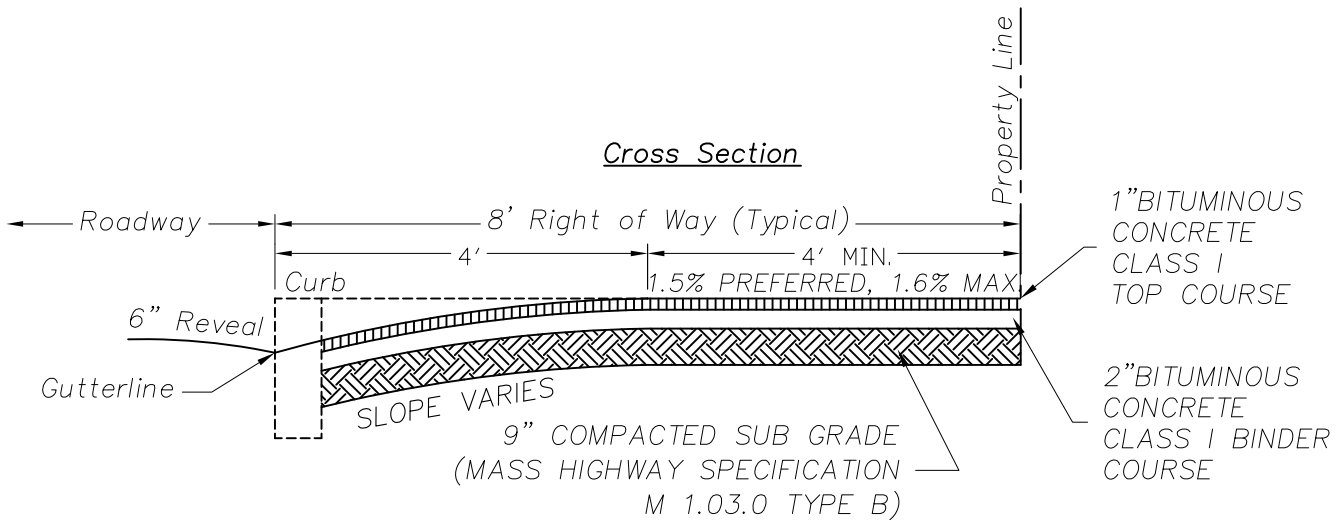

All construction must be in compliance with the Americans with Disabilities Act (ADA).



TOWN OF WELLESLEY
DEPARTMENT OF PUBLIC WORKS
ENGINEERING DIVISION
COMMERCIAL DRIVEWAY APRON STANDARDS
FOR NEW DEVELOPMENTS

2G

DATE: 01/18/2002
DATE REVISED: 01/26/2011

SCALE: NONE

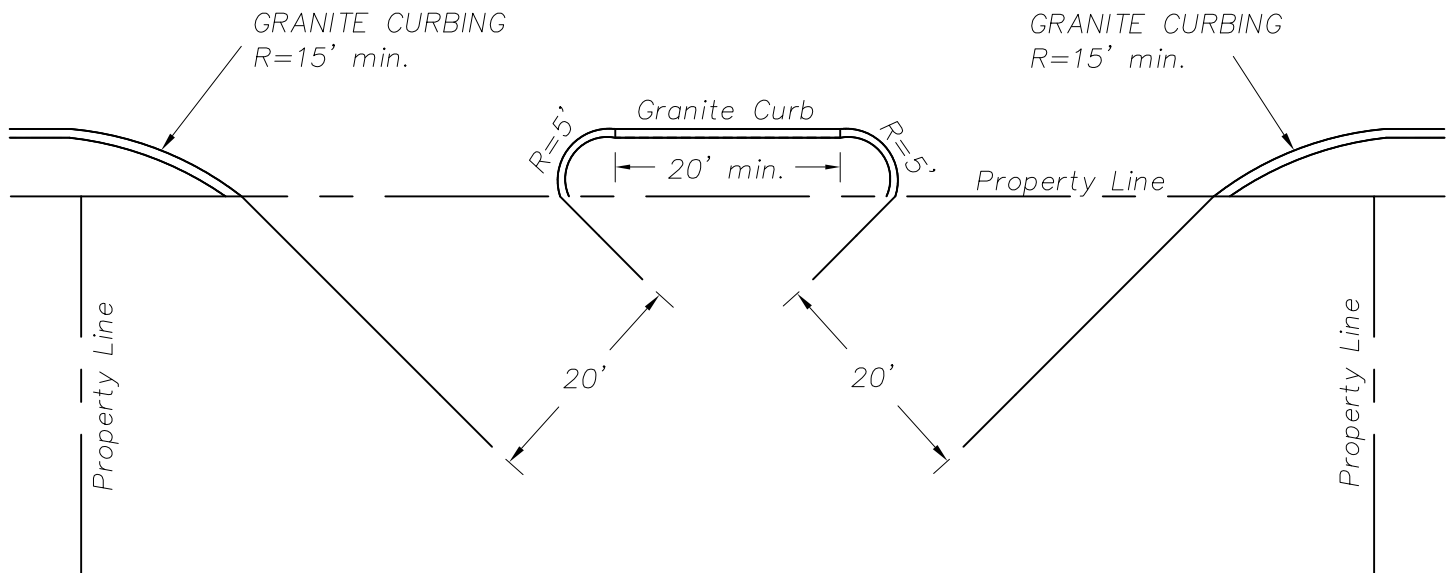

All construction must be in compliance with the Americans with Disabilities Act (ADA).